

RECLAIM OF X-RAY TARGETS

Reclaim can give the target multiple lives. In addition to the financial benefits reclaim is part of a sustainable development approach by reducing the use of virgin materials in target production.

Currently, ACERDE reclaims anodes with a diameter range from 60 to 200 mm, including those with brazed graphite.

In the future, the target reclaim range will be extended to lightweight targets with graphite or composite substrates.

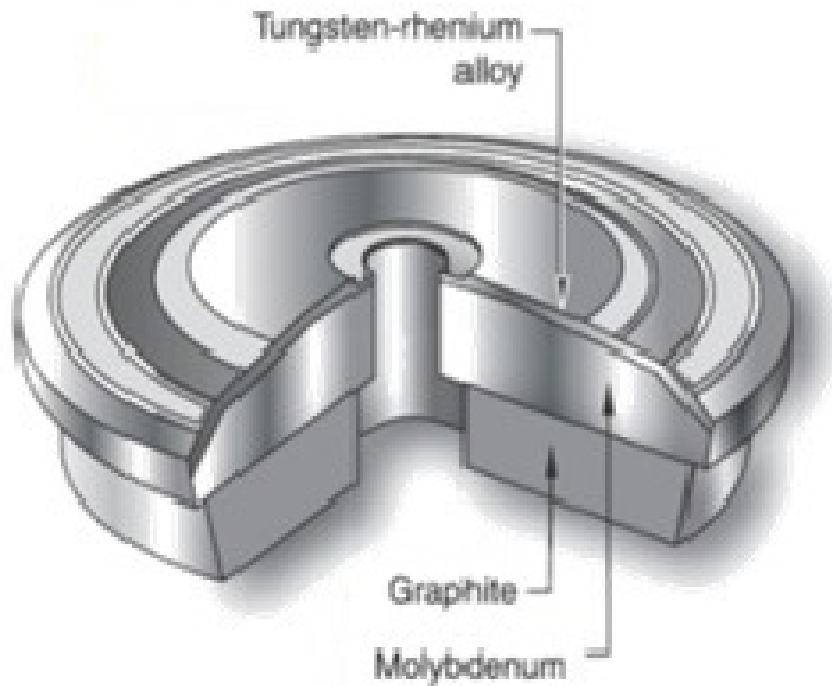

APPLICATIONS

FOR MEDICAL IMAGING



The light rotating X-ray targets are used in X-ray tubes which are an essential part of the following imaging technology:

- CT scanners
- Angiography
- Mammography
- Cardiology
- General purpose X-ray

FOR OTHER INDUSTRIAL APPLICATIONS

Other industrial applications that utilize X-Ray tubes:

- Non destructive control
- Security control (airport, ...)

CVD PROCESS APPLICATIONS

ACERDE proceeds to Tungsten-Rhenium (WRe) coatings.

The ACERDE's know-how in CVD and HTCVD (High Temperature Chemical Vapor Deposition) mainly surrounds mold coatings, medical, aeronautic, precision and electronics industries. For those industries, the HTCVD technology has attractive characteristics. CVD is particularly useful in the following applications:

